

ASME B18.2.4.6M-2010
[Revision of ANSI B18.2.4.6M-1979 (R2003)]

Metric Heavy Hex Nuts

AN AMERICAN NATIONAL STANDARD



The American Society of
Mechanical Engineers



INTENTIONALLY LEFT BLANK

ASME B18.2.4.6M-2010
[Revision of ANSI B18.2.4.6M-1979 (R2003)]

Metric Heavy Hex Nuts

AN AMERICAN NATIONAL STANDARD



**The American Society of
Mechanical Engineers**



Date of Issuance: March 31, 2010

This Standard will be revised when the Society approves the issuance of a new edition. There will be no addenda issued to this edition.

ASME issues written replies to inquiries concerning interpretations of technical aspects of this Standard. Periodically certain actions of the ASME B18 Committee may be published as Cases. Cases and interpretations are published on the ASME Web site under the Committee Pages at <http://cstools.asme.org> as they are issued.

ASME is the registered trademark of The American Society of Mechanical Engineers.

This code or standard was developed under procedures accredited as meeting the criteria for American National Standards. The Standards Committee that approved the code or standard was balanced to assure that individuals from competent and concerned interests have had an opportunity to participate. The proposed code or standard was made available for public review and comment that provides an opportunity for additional public input from industry, academia, regulatory agencies, and the public at large.

ASME does not “approve,” “rate,” or “endorse” any item, construction, proprietary device, or activity.

ASME does not take any position with respect to the validity of any patent rights asserted in connection with any items mentioned in this document, and does not undertake to insure anyone utilizing a standard against liability for infringement of any applicable letters patent, nor assumes any such liability. Users of a code or standard are expressly advised that determination of the validity of any such patent rights, and the risk of infringement of such rights, is entirely their own responsibility.

Participation by federal agency representative(s) or person(s) affiliated with industry is not to be interpreted as government or industry endorsement of this code or standard.

ASME accepts responsibility for only those interpretations of this document issued in accordance with the established ASME procedures and policies, which precludes the issuance of interpretations by individuals.

No part of this document may be reproduced in any form,
in an electronic retrieval system or otherwise,
without the prior written permission of the publisher.

The American Society of Mechanical Engineers
Three Park Avenue, New York, NY 10016 5990

Copyright © 2010 by
THE AMERICAN SOCIETY OF MECHANICAL ENGINEERS
All rights reserved
Printed in U.S.A.

CONTENTS

Foreword	iv
Committee Roster	v
Correspondence With the B18 Committee	vii
1 Scope	1
2 Comparison With ISO Standards	1
3 Referenced Standards	1
4 Terminology	1
5 Dimensions	1
6 Width Across Flats	1
7 Thickness	1
8 Tops and Bearing Surfaces	1
9 Corner Fill	2
10 True Position of Hexagon to the Tapped Hole	2
11 Countersink	2
12 Threads	2
13 Material and Mechanical Properties	2
14 Finish	2
15 Identification Symbols	2
16 Inspection and Quality Assurance	2
17 Designation	2
18 Workmanship	2
Table	
1 Dimensions of Heavy Hex Nuts	3
Nonmandatory Appendix	
A General Dimension Requirements From ISO 4775	5

FOREWORD

The B18 American National Standards Committee for the standardization of bolts, screws, nuts, rivets, and similar fasteners was organized in March 1922, as Sectional Committee B18 under the aegis of the American Engineering Standards Committee (later the American Standards Association, then the United States of America Standards Institute, and as of October 6, 1969, the American National Standards Institute, Inc.), with the Society of Automotive Engineers and the American Society of Mechanical Engineers as joint sponsors. B18 Subcommittee 2 was subsequently established and charged with the responsibility for technical content of standards covering wrench head bolts and nuts.

At its meeting on December 4, 1974, the B18 Committee authorized preparation of a series of standards for metric fasteners. Subcommittee 2 was assigned responsibility for developing standards for metric hex bolts, screws, and nuts.

At a meeting on September 22, 1976, Subcommittee 2 organized the contents of a standard covering six different styles of hex nuts. Actual drafting was postponed until ISO/TC2 could reach final decisions relating to basic dimensions and characteristics of hex bolts, screws, and nuts. At ISO/TC2 meetings held in April 1977, final actions were taken. The B18 Committee affirmed the TC2 decisions at a meeting on June 29, 1977, and drafting of this Standard was started.

In February 1978, the B18 Committee established a cooperative program with the Department of Defense to draft American National Standards for metric fasteners in such a way that they could be used directly by the Government for procurement purposes. The Department of Defense requested that each of the six nut products be covered in separate standards, and Subcommittee 2 accepted this approach at its meeting on June 27, 1978.

This Standard was approved by letter ballot of the B18 Committee on July 2, 1979, and was subsequently approved by the secretariats and submitted to the American National Standards Institute for designation as an American National Standard. This was granted on December 6, 1979.

In March 2007, B18 Subcommittee 2 decided to start a major revision of the Standard. The scope was revised to include the range of nuts from M12 through M100, dimensional differences were coordinated to the extent possible with ISO 4775, the referenced standards were specifically identified, the terminology was referenced specifically to ASME B18.12, symbols specifying geometric characteristics were made in accordance with ASME Y14.5, stainless steel and nonferrous nuts were conformed to the requirements of ASTM F 836M, stainless steel and nonferrous nuts were marked to identify the property class and manufacturer in accordance with requirements specified in ASTM F 836M or ASTM F 467M, acceptability of nuts was determined in accordance with ASME B18.18.2, a reference was made for the recommended B18 (PIN) for metric heavy hex nuts and was included in ASME B18.24, a workmanship reference to ASTM F 812/F 812M was added, Table 1 was enhanced to include symbols specifying geometric characteristics per ASME Y14.5, the table in Nonmandatory Appendix A was added to assist in determining the dimensional differences between ASME B18.2.4.6M and ISO 4775, and Appendix 1 and Table 2 were removed.

This Standard was approved by the American National Standards Institute on February 22, 2010.

ASME B18 COMMITTEE

Standardization of Bolts, Nuts, Rivets, Screws, Washers, and Similar Fasteners

(The following is the roster of the Committee at the time of approval of this Standard.)

STANDARDS COMMITTEE OFFICERS

J. Greenslade, *Chair*
D. S. George, *Vice Chair*
R. D. Strong, *Vice Chair*
C. J. Gomez, *Secretary*

STANDARDS COMMITTEE PERSONNEL

V. Cartina , Consultant	J. F. Koehl , <i>Contributing Member</i> , Spirol International Corp.
D. A. Clever , Consultant	W. H. Kopke , Consultant
A. P. Cockman , Ford Motor Co.	W. J. Lutkus , Emhart Teknologies
C. A. Dugal , TSP, Inc.	D. A. McCrindle , Canadian Fasteners Institute
J. S. Foote , <i>Contributing Member</i> , Trade Association Management, Inc.	M. D. Prasad , <i>Contributing Member</i> , Global M&F Solutions
D. S. George , ND Industries	S. Savoji , ITW Medalist
C. J. Gomez , The American Society of Mechanical Engineers	W. Schevey , <i>Contributing Member</i> , BGM Fastener Co., Inc.
J. Greenslade , Industrial Fasteners Institute	Q. M. Smith III , Oregon Department of Transportation
J. J. Grey , <i>Contributing Member</i> , Fastener Consulting Services, Inc.	W. R. Stevens , Ramco
B. Hasiuk , <i>Contributing Member</i> , Defense Supply Center Philadelphia	R. D. Strong , General Motors Corp.
A. Herskovitz , Consultant	S. W. Vass , Consultant
J. Hubbard , Leland Powell Fastener, Inc.	C. B. Wackrow , <i>Contributing Member</i> , MNP Corp.
J. Jennings , <i>Contributing Member</i> , Naval Surface Warfare Center	W. K. Wilcox , Consultant
W. H. King , Porteous Fasteners Co.	C. B. Williamson , Fastenal Co.
	C. J. Wilson , Consultant
	R. B. Wright , <i>Contributing Member</i> , Wright Tool Co.
	J. G. Zeratsky , National Rivet and Manufacturing Co.

SUBCOMMITTEE 16 — NUTS

W. R. Stevens , <i>Chair</i> , Ramco	J. Jennings , Naval Surface Warfare Center
V. Cartina , <i>Vice Chair</i> , Consultant	J. F. McCarrick , Defense Supply Center Philadelphia
A. P. Cockman , Ford Motor Co.	W. L. Sakowski , Account Managers, LLC
B. A. Dusina , Federal Screw Works	R. M. Serabin , Freundlich Supply Co.
M. A. Elmi , Caterpillar	D. F. Sharp , GMS Structural Engineers
D. S. George , ND Industries	D. J. Soccia , Electric Boat Corp.
J. Greenslade , Industrial Fasteners Institute	W. K. Wilcox , Consultant
J. J. Grey , Fastener Consulting Services, Inc.	C. B. Williamson , Fastenal Co.
	C. J. Wilson , Consultant

CORRESPONDENCE WITH THE B18 COMMITTEE

General. ASME Standards are developed and maintained with the intent to represent the consensus of concerned interests. As such, users of this Standard may interact with the Committee by requesting interpretations, proposing revisions, and attending Committee meetings. Correspondence should be addressed to:

Secretary, B18 Standards Committee
The American Society of Mechanical Engineers
Three Park Avenue
New York, NY 10016-5990
<http://go.asme.org/Inquiry>

Proposing Revisions. Revisions are made periodically to the Standard to incorporate changes that appear necessary or desirable, as demonstrated by the experience gained from the application of the Standard. Approved revisions will be published periodically.

The Committee welcomes proposals for revisions to this Standard. Such proposals should be as specific as possible, citing the paragraph number(s), the proposed wording, and a detailed description of the reasons for the proposal, including any pertinent documentation.

Proposing a Case. Cases may be issued for the purpose of providing alternative rules when justified, to permit early implementation of an approved revision when the need is urgent, or to provide rules not covered by existing provisions. Cases are effective immediately upon ASME approval and shall be posted on the ASME Committee Web page.

Requests for Cases shall provide a Statement of Need and Background Information. The request should identify the standard, the paragraph, figure or table number(s), and be written as a Question and Reply in the same format as existing Cases. Requests for Cases should also indicate the applicable edition(s) of the standard to which the proposed Case applies.

Interpretations. Upon request, the B18 Standards Committee will render an interpretation of any requirement of the Standard. Interpretations can only be rendered in response to a written request sent to the Secretary of the B18 Standards Committee.

The request for an interpretation should be clear and unambiguous. It is further recommended that the inquirer submit his/her request in the following format:

Subject: Cite the applicable paragraph number(s) and the topic of the inquiry.
Edition: Cite the applicable edition of the Standard for which the interpretation is being requested.
Question: Phrase the question as a request for an interpretation of a specific requirement suitable for general understanding and use, not as a request for an approval of a proprietary design or situation. The inquirer may also include any plans or drawings, which are necessary to explain the question; however, they should not contain proprietary names or information.

Requests that are not in this format may be rewritten in the appropriate format by the Committee prior to being answered, which may inadvertently change the intent of the original request.

ASME procedures provide for reconsideration of any interpretation when or if additional information that might affect an interpretation is available. Further, persons aggrieved by an interpretation may appeal to the cognizant ASME Committee or Subcommittee. ASME does not "approve," "certify," "rate," or "endorse" any item, construction, proprietary device, or activity.

Attending Committee Meetings. The B18 Standards Committee regularly holds meetings that are open to the public. Persons wishing to attend any meeting should contact the Secretary of the B18 Standards Committee.

METRIC HEAVY HEX NUTS

1 SCOPE

(a) This Standard covers the complete general and dimensional data for metric heavy hex nuts M12 through M100 recognized as American National Standard.

(b) The inclusion of dimensional data in this Standard is not intended to imply that all of the nut sizes in conjunction with various options described herein are stock items. Purchasers should consult with suppliers concerning lists of stock production heavy hex nuts.

2 COMPARISON WITH ISO STANDARDS

Heavy hex nuts in normal thread diameters M12 through M36 as covered in this Standard have been coordinated to the extent possible with ISO 4775 (see Appendix A for dimensional differences).

3 REFERENCED STANDARDS

The following is a list of publications referenced in this Standard.

- ASME B1.13M, Metric Screw Threads: M Profile
 ASME B18.12, Glossary of Terms for Mechanical Fasteners
 ASME B18.18.2, Inspection and Quality Assurance for High-Volume Machine Assembly Fasteners
 ASME B18.24, Part Identifying Number (PIN) Code System Standard for B18 Fastener Products
 ASME Y14.5-2009, Dimensioning and Tolerancing
 Publisher: The American Society of Mechanical Engineers (ASME), Three Park Avenue, New York, NY 10016-5990; Order Department: 22 Law Drive, Box 2300, Fairfield, NJ 07007-2300 (www.asme.org)
- ASTM A 563M, Carbon and Alloy Steel Nuts [Metric]
 ASTM F 467M, Nonferrous Nuts for General Use [Metric]
 ASTM F 812/F 812M, Surface Discontinuities of Nuts, Inch and Metric Fasteners
 ASTM F 836M, Standard Specification for Style 1 Stainless Steel Metric Nuts
 ASTM F 1941M, Electrodeposited Coatings on Threaded Fasteners [Metric]
 Publisher: The American Society for Testing and Materials (ASTM International), 100 Barr Harbor Drive, West Conshohocken, PA 19428 (www.astm.org)
- ISO 4775, Hexagon Nuts for High-Strength Structural Bolting with Large Width-Across-Flats Product Grade B — Property Classes 8 and 10

Publisher: International Organization for Standardization (ISO), 1, ch. de la Voie-Creuse, Case Postale 56, CH-1211, Genève 20, Switzerland/Suisse (www.iso.org)

4 TERMINOLOGY

For definitions of terms relating to fasteners or component features thereof used in this Standard, refer to ASME B18.12.

5 DIMENSIONS

(a) Unless otherwise stated, all dimensions in this Standard are in millimeters and apply before any coating. When plating or coating is specified, the finished product dimensions shall be as agreed upon between supplier and purchaser.

(b) Symbols specifying geometric characteristics are in accord with ASME Y14.5.

6 WIDTH ACROSS FLATS

(a) The width across flats shall be the distance, measured perpendicular to the axis of the nut, between two opposite wrenching flats.

(b) The minimum width across flats does not apply for 25% of the minimum nut thickness as measured from either face.

(c) On nonferrous products where milled-from-bar material is used, the dimensions across flats may be modified to conform to the dimensions of the bar material when agreed to between the purchaser and the supplier.

7 THICKNESS

The nut thickness shall be the overall distance, measured parallel to the axis of the nut, from the top of the nut to the bearing surface, and include the thickness of the washer face where provided, but exclude raised identification markings, where they are permitted.

8 TOPS AND BEARING SURFACES

(a) Nuts shall be either double chamfered or have a washer faced bearing surface and a chamfered top.

(b) The diameter of the bearing surface shall not exceed the width across flats nor be less than the bearing face diameter specified in Table 1. The measurement of

the bearing surface diameter shall be taken at 0.1 mm below the bearing surface as shown in Table 1.

(c) Within the minimum diameter, D_w , the bearing surface shall be flat and perpendicular to the axis of the thread pitch diameter within the total runout limit specified in Table 1.

(d) The tops of washer faced nuts shall be flat and the diameter of the chamfer circle shall be equal to the maximum width across flats within a tolerance of -15% .

(e) The length of chamfer at hex corners shall be from 5% to 15% of the nominal thread diameter. The surface of the chamfer may be slightly convex or rounded.

9 CORNER FILL

A rounding or lack of fill at the junction of hex corners with the chamfer shall be permissible provided the width across corners is within specified limits at beyond a distance equal to 17.5% of the nominal thread diameter from the chamfered face.

10 TRUE POSITION OF HEXAGON TO THE TAPPED HOLE

The runout of the flats of the nut shall not be greater than 2% of the maximum width across flats with respect to the axis of the thread pitch diameter.

11 COUNTERSINK

The tapped hole shall be countersunk on the bearing face(s). The countersink included reference angle shall be 90 deg to 120 deg. The maximum countersink diameter shall be 1.08 times the nominal thread diameter; the minimum countersink diameter shall be the nominal thread diameter.

12 THREADS

(a) Threads shall be metric coarse threads with class 6H tolerances in accordance with ASME B1.13M.

(b) Nuts intended for use with externally threaded fasteners which are plated or coated with a plating or coating thickness (e.g., hot-dip galvanized) requiring overtapping of the nut thread to permit assembly shall have overtapped threads in conformance with requirements specified in ASTM A 563M.

13 MATERIAL AND MECHANICAL PROPERTIES

Carbon and alloy steel nuts shall conform to the requirements specified in ASTM A 563M. Stainless steel and nonferrous nuts shall conform to the requirements of ASTM F 836M and ASTM F 467M, respectively.

14 FINISH

Unless otherwise specified, nuts shall be furnished with a natural (as processed) finish, unplated or uncoated.

15 IDENTIFICATION SYMBOLS

(a) Unless otherwise specified, carbon and alloy steel nuts shall be marked to identify the property class and manufacturer in accordance with requirements specified in ASTM A 563M. Stainless steel and nonferrous nuts shall be marked to identify the property class and manufacturer in accordance with requirements specified in ASTM F 836M or ASTM F 467M, respectively.

(b) Nuts of other materials shall be identified for property class and manufacturing source as agreed between the manufacturer and purchaser.

16 INSPECTION AND QUALITY ASSURANCE

Unless otherwise specified by the purchaser in the original inquiry and purchase order, acceptability of nuts shall be determined in accordance with ASME B18.18.2.

17 DESIGNATION

(a) Heavy hex nuts shall be designated by the following data, preferably in the sequence shown: product name, designation of Standard (ASME B18.2.4.6M), nominal diameter and thread pitch, steel property class or material identification, and protective coating if required.

NOTE: It is common practice in ISO Standards to omit thread pitch from the product designation when screw threads are the metric coarse thread series (e.g., M10 is M10 \times 1.5).

EXAMPLE: Heavy Hex Nuts, ASME B18.2.4.6M, M10 \times 1.5, ASTM A 563M Class 9, zinc plated per ASTM F 1941M Fe/Zn5C

(b) The recommended B18 part identifying numbering system (PIN) for metric heavy hex nuts is included in ASME B18.24. This system may be used by any user needing a definitive part numbering system.

18 WORKMANSHIP

Nuts shall be free of surface irregularities which might affect their serviceability, such as burrs, seams, laps, loose scale, and other irregularities. Unless otherwise specified, surface discontinuities shall conform to the requirements of ASTM F 812/F 812M.

Table 1 Dimensions of Heavy Hex Nuts

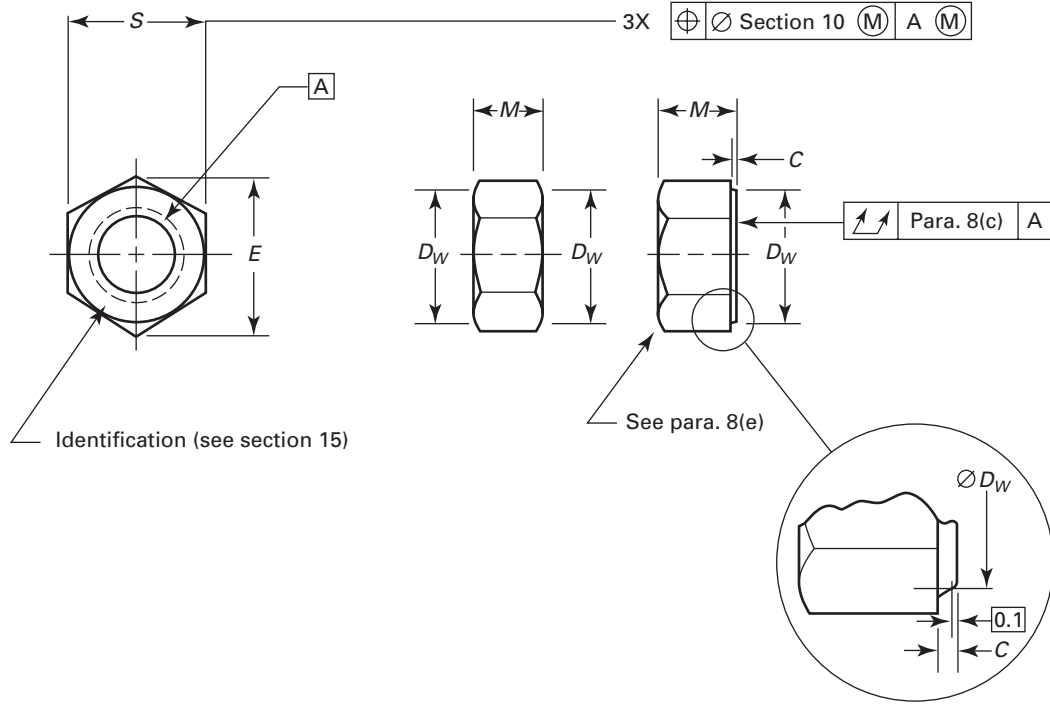

Nominal Nut Dia. and Thread Pitch	Width Across Flats, S		Width Across Corners, E		Thickness, M		Minimum Bearing Face Dia., D_w	Washer Face Thickness, C		Maximum Total Runout of Bearing Surface FIM
	Max.	Min.	Max.	Min.	Max.	Min.		Max.	Min.	
M12 × 1.75	21.00	20.16	24.25	22.78	12.3	11.9	19.2	0.8	0.4	0.38
M14 × 2	24.00	23.16	27.71	26.17	14.3	13.6	22.0	0.8	0.4	0.42
M16 × 2	27.00	26.16	31.18	29.56	17.1	16.4	24.9	0.8	0.4	0.47
M20 × 2.5	34.00	33.00	39.26	37.29	20.7	19.4	31.4	0.8	0.4	0.58
M22 × 2.5	36.00	35.00	41.57	39.55	23.6	22.3	33.3	0.8	0.4	0.63
M24 × 3	41.00	40.00	47.34	45.20	24.2	22.9	38.0	0.8	0.4	0.72
M27 × 3	46.00	45.00	53.12	50.85	27.5	26.3	42.8	0.8	0.4	0.80
M30 × 3.5	50.00	49.00	57.74	55.37	30.7	29.1	45.6	0.8	0.4	0.87
M36 × 4	60.00	58.80	69.28	66.44	36.6	35.0	55.9	0.8	0.4	1.05
M42 × 4.5	70.00	67.90	80.83	77.41	42.0	40.4	64.5	1.0	0.5	1.22
M48 × 5	80.00	77.60	92.38	88.46	48.0	46.4	73.7	1.0	0.5	1.40
M56 × 5.5	90.00	87.20	103.92	99.41	56.0	54.1	82.8	1.0	0.5	1.57
M64 × 6	100.00	96.80	115.47	110.35	64.0	62.1	92.0	1.0	0.5	1.75
M72 × 6	110.00	106.40	127.02	121.30	72.0	70.1	101.1	1.2	0.6	1.92
M80 × 6	120.00	116.00	138.56	132.24	80.0	78.1	110.2	1.2	0.6	20.9
M90 × 6	135.00	130.50	155.88	148.77	90.0	87.8	124.0	1.2	0.6	2.36
M100 × 6	150.00	145.00	173.21	165.30	100.0	97.8	137.8	1.2	0.6	2.62
Refer to section	6		9		7		8	8		8

INTENTIONALLY LEFT BLANK

NONMANDATORY APPENDIX A GENERAL DIMENSION REQUIREMENTS FROM ISO 4775

The general dimensional requirements of ISO 4775 have been provided below to assist in determining the dimensional differences between ASME B18.2.4.6M and ISO 4775.

Table A-1 General Dimensions

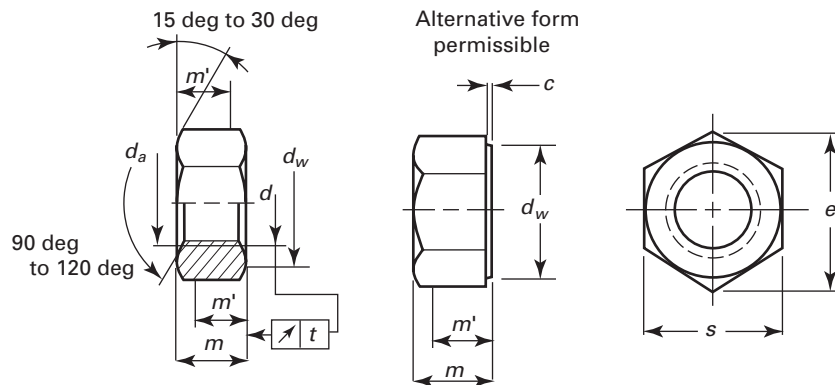

Thread Size, d	P [Note (1)]	d_a		d_w		e , Min.	m		m' , Min.	c		s		t
		Max.	Min.	Max.	Min.		Max.	Min.		Max.	Min.			
M12 [Note (2)]	1,75	13	12	[Note (3)]	19,2	22,78	12,3	11,9	9,5	0,8	0,4	21	20,16	0,38
M16	2	17,3	16	[Note (3)]	24,9	29,56	17,1	16,4	13,1	0,8	0,4	27	26,16	0,47
M20	2,5	21,6	20	[Note (3)]	31,4	37,29	20,7	19,4	15,5	0,8	0,4	34	33	0,58
M22 [Note (4)]	2,5	23,8	22	[Note (3)]	33,3	39,55	23,6	22,3	17,8	0,8	0,4	36	35	0,63
M24	3	25,9	24	[Note (3)]	38,0	45,20	24,2	22,9	18,3	0,8	0,4	41	40	0,72
M27 [Note (4)]	3	28,2	27	[Note (3)]	42,8	50,85	27,6	26,3	21,0	0,8	0,4	46	45	0,80
M30	3,5	32,4	30	[Note (3)]	46,5	55,37	30,7	29,1	23,3	0,8	0,4	50	49	0,87
M36	4	38,9	36	[Note (3)]	55,9	66,44	36,6	35,0	28,0	0,8	0,4	60	58,8	1,05

GENERAL NOTES:

- (a) For hot dip galvanized nuts, the above dimensions apply before galvanizing.
- (b) The only dimensional differences between ASME B18.2.4.6M and ISO 4775 are that ASME B18.2.4.6M does not specify diameter, d_a , wrenching height, m' , and the chamfer angle.

NOTES:

- (1) P = pitch of thread.
- (2) Nonpreferred for technical reasons.
- (3) d_w max. = s actual
- (4) Indicates second choice diameter.

INTENTIONALLY LEFT BLANK

INTENTIONALLY LEFT BLANK

ASME B18.2.4.6M-2010

ISBN 978-0-7918-3290-5



9 780791 832905



M11610